

U-Type URETHANE CLEANER

This cleaner is characterized by having a polyurethane blade with sintered tungsten carbide tip. Its spring tensioners allow a constant pressure between the blade and the belt.

The design of the set facilitates the replacement of the blade, minimizing maintenance and repair costs.

The application of the U-type cleaner is intended for belts of widths less than 2000 mm (80 in), belt speeds up to 6.1 m/s (1200 FPM), and temperature ranges between -28° / 108° C (-20° / 225° F).

SELECTION GUIDE

For the proper selection of a U-type belt cleaner, the following data is required:

- . Belt width.
- . Head pulley diameter.
- . Speed of the conveyor belt.
- . Type of bulk material.
- . Operating temperature.

Once the data of the belt conveyor has been collected, proceed as follows:

1. The type of blade is chosen according to the characteristics of the conveyor, in particular depending on the width of the belt (See Table 6)

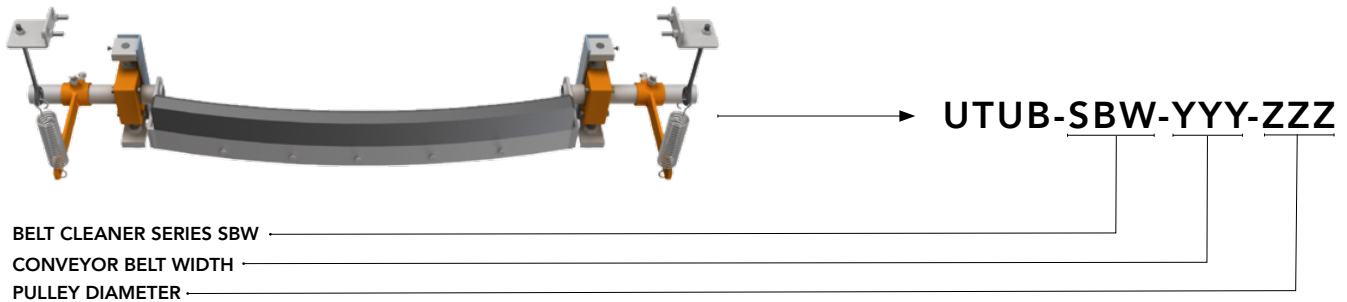

Table 6. Selection guide to determine U-type belt cleaner

Model	Belt width, mm (in)	Discharge chute width, mm (in)
UTUB-SBW-800	800 (32)	1600 (64)
UTUB-SBW-1000	1000 (40)	1800 (72)
UTUB-SBW-1200	1200 (48)	2160 (86)
UTUB-SBW-1400	1400 (56)	2360 (94)
UTUB-SBW-1600	1600 (64)	2560 (102)
UTUB-SBW-1800	1800 (72)	2760 (110)
UTUB-SBW-2000	2000 (80)	2960 (118)
UTUB-SBW-2200	2200 (88)	3160 (126)

