



# BELT CLEANER SYSTEMS

CONVEYOR BELT SYSTEMS  
DESIGN, FABRICATION AND SUPPLY OF CONVEYOR BELTS

WWW.LUFH-CBS.COM





LUFH



# INDEX

<b>LUFH-CBS</b> .....	<b>04</b>
<b>BENEFITS OF BELT CLEANERS</b> .....	<b>05</b>
<b>BELT CLEANER CHARACTERISTICS</b> .....	<b>06</b>
PRINCIPLES FOR EFFECTIVE CLEANING OF CONVEYOR BELTS	
Positioning of Belt Cleaners	
<b>PRIMARY BELT CLEANERS</b> .....	<b>09</b>
URETHANE CLEANERS	
Selection Guide	
Types of Urethane Blade	
H-TYPE RAZOR-BACK BELT CLEANERS	
Selection Guide	
Type of H Blades	
<b>SECONDARY BELT CLEANERS</b> .....	<b>15</b>
P-TYPE RUBBER BLADE RAZOR-BACK BELT CLEANERS	
Selection Guide	
P-TYPE URETHANE BLADE RAZOR-BACK BELT CLEANERS	
Selection Guide	
U-TYPE URETHANE CLEANER	
Selection Guide	
<b>SPECIALTY CLEANERS</b> .....	<b>20</b>
CERAMIC SCRAPER BELT CLEANERS	
Selection Guide	
C-TYPE BELT CLEANERS	
Selection Guide	
<b>TENSIONER DEVICES</b> .....	<b>23</b>
PRIMARY TENSORS	
Rubber Tensors	
Spring Tensors	
SECONDARY TENSORS	
Rubber Tensors	
Spring Tensors	
<b>BELT CLEANER DATA SHEET COLLECTION</b> .....	<b>26</b>

# LUFH-CBS

LUFH Conveyor Belt Systems, supplies high quality and top performance conveyor belts and conveyor system components, with excellent follow-through technical support and after-sales service. Our products are specialized for the oil, mining, industrial and construction fields, thus fulfilling the applicable requirements of the interested parties to the client's satisfaction. LUFH seeks excellence through continuous improvement of the Quality Management System by employing highly competent and motivated human talent, and by having adequate facilities and instruments that allow us to meet high quality standards.

Our technical department is able to provide improvement proposals based on an innovative approach and adapting to the needs or demands of the client. We put special emphasis on meeting customer requirements with reliability and punctuality, providing guarantee and after-sales service.

**"Seeking excellency through the continuous improvement of the Quality Management System"**





## Benefits of

# BELT CLEANERS

The use of belt cleaners allows the operation of the conveyor belt to be cleaner, safer and more productive. Belt cleaners represent an intelligent investment and over time allow money savings, since.

### It Increases belt life span.

- Reduces the amount of spilled material that accumulates in the plant, reducing damage to the belt, rollers and other components.
- Improves maintenance planning with a reduction in the number of emergency failures and other temporary repairs
- Increase conveyor efficiency by reducing unscheduled interruptions.
- Reduces maintenance costs as it reduces the amount of components that are changed due to premature wear.
- Decrease the amount of man hours invested in the cleaning of spilled material in the conveyor areas.
- Increases safety on the conveyor by improving working conditions and reducing the amount of accidents resulting from spilled material and suspended dust.
- Reduces environmental and labor problems due to a better control of suspended dust.

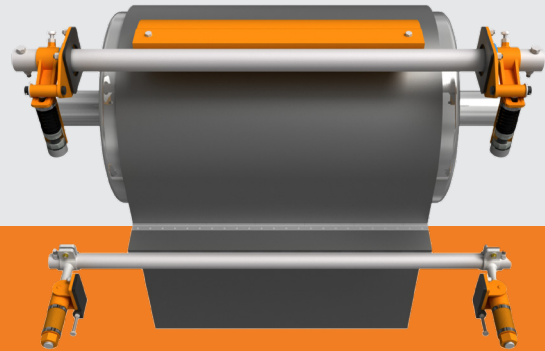

**LUFH-CBS offers innovative solutions in belt cleaners for different conveyor belt satisfying the needs and requirements of the client.**

## Belt cleaner

# CHARACTERISTICS

The greatest amount of material spilled on a conveyor, under normal operating conditions, occurs when the fine material that is attached to the belt is released during the return path. The spillage of this fine material can cause different problems such as: <sup>1)</sup> stacking of material under the conveyor; <sup>2)</sup> adhesion of material to rotating components - such as rollers and pulleys - that accelerate its wear and deform its geometry; <sup>3)</sup> misalignment in the belt; <sup>4)</sup> exposure of personnel to risk conditions due to particles and floating dust, and <sup>5)</sup> environmental impact due to suspended dust.

To reduce spillage problems, belt cleaners are used to improve conveyor performance, reduce maintenance costs and mitigate the environmental impact of the plant. These have application in coal plants, steel mills, iron mines, and other mining industries. The effectiveness of belt cleaners varies significantly with their design and correct selection. Most remove the bonded material by scraping or brushing the surface of the belt as it leaves the head pulley, where the material is discharged and begins the return path of the belt under the conveyor.

**“Belt cleaners are used to improve conveyor performance, reduce maintenance costs and mitigate the environmental impact of the plant.”**





## Principles for effective CLEANING OF CONVEYOR BELTS

The proper selection and optimal operation of the belt cleaner includes the characteristics of the conveyor system, the type of bulk material transported and the service conditions.

### Positioning of belt cleaners

For effective cleaning, the location of the belt cleaners must take into account the following considerations:



#### Close to material discharge

- Belt cleaners should be placed as close as possible to the discharge of the material to avoid spills outside the discharge chute.



#### Away from material flow

- Belt cleaners must be installed outside the material flow to avoid impacts and spills.



#### Minimum belt risk

- Belt cleaners must be installed properly to prevent risk of damage to the belt, its splice and the cleaning blade itself due to excess pressure.



#### Easy and fast maintenance

- The belt cleaners must have a simple maintenance that allows a quick replacement of your cleaning blade in case of wear and minimum adjustment of tension on the conveyor belt.



Depending on the location on the conveyor, THE BELT CLEANERS ARE CLASSIFIED AS:

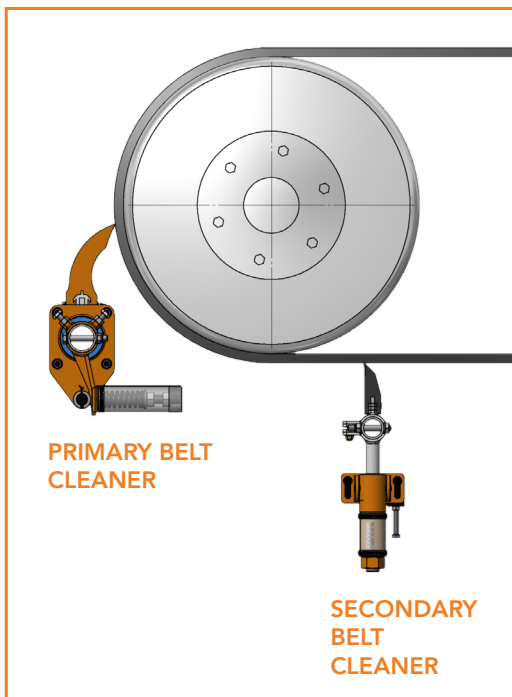
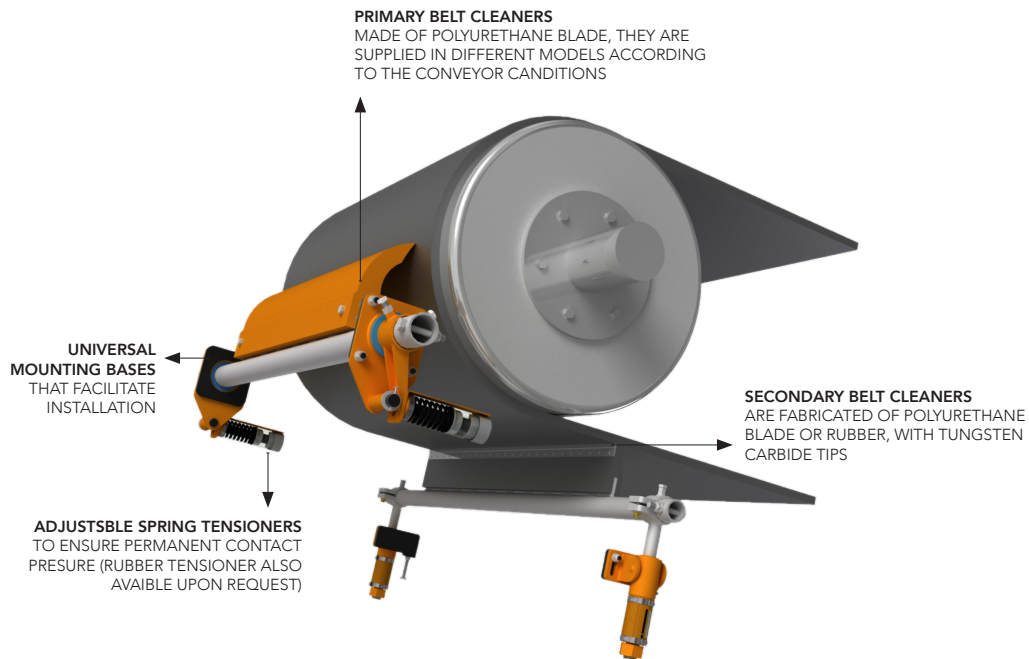

### Primary belt CLEANERS

if it is located on the front of the pulley in the discharge chute, which removes most of the material adhered to the surface of the belt.

### Secondary belt CLEANERS

if it is located in the lower part of the belt in the area of the discharge chute, removing the material that could not be removed by the primary system. If material conditions are adverse, additional belt cleaners known as tertiary will be required.

At LUFH-CBS, we offer different solution alternatives according to the cleaning needs your conveyor belt requires.





**PRIMARY  
BELT CLEANER**



The primary cleaning system is the first cleaning element that removes most of the material adhered to the conveyor belt, leaving only a thin layer of fine grain.

These belt cleaners press against the conveyor belt usually at low pressure. Given the low pressure between the primary cleaning system blade and the belt, these cleaners are installed at an attack angle with respect to the belt, which facilitates the release of the material. The use of higher pressure may compromise the life of the belt, its splice or the belt cleaner itself.

This cleaning element is placed in front of the conveyor head pulley, below the material discharge parabola. By design, the location of the primary belt cleaner is out of the material flow to prevent its accumulation, as well as impacts on the blade.





# Urethane CLEANERS

The urethane cleaners are devices specially designed to absorb impacts and let pass the splices of the belts without any damage.

The polyurethane blade offers a long service life to the cleaning system. The blade can be replaced quickly, reducing maintenance and repair costs.

LUFH models are available for conveyor belts width from 300 to 2200 mm (12 to 84 in), and can operate with belt speeds of 6.1 m/s (1200 FPM) and temperatures between -20 ° / 148 ° C (-20 ° / 300 ° F).

## SELECTION GUIDE

For the proper selection of a primary urethane belt cleaner, the following data is required:

- . Belt width.
- . Pulley diameter where the system will be installed.
- . Speed of the conveyor belt.
- . Type of bulk material.
- . Operating temperature.

Once the data of the conveyor has been collected, proceed as follows:

1. The required number of the blade size is chosen according to the width of the belt and the diameter of the head pulley (See Table 1).
2. The selection of the urethane cleaner is corroborated with the maximum speed of the belt (See Figure 1).

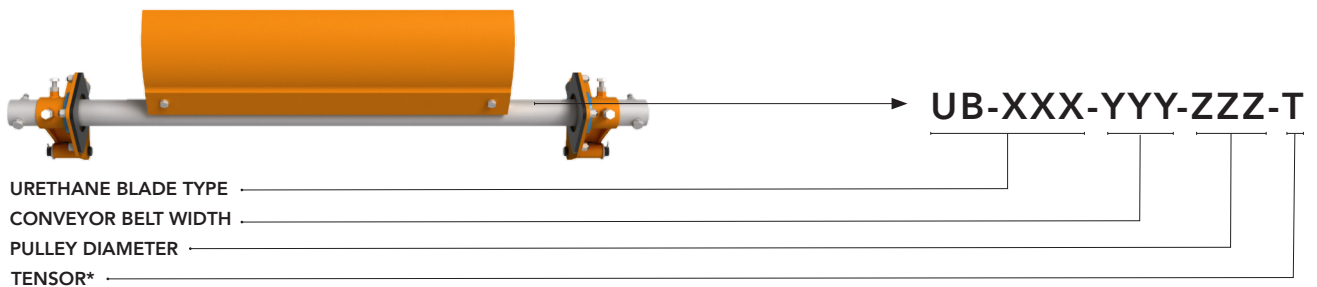

\* See section Tensioners Devices for coding of available tensioners. If you wish to receive help in the selection, you can consult the Technical Department of LUFH-CBS.

**TABLE 1** Selection guide for primary urethane belt cleaner

Belt width		HEAD PULLEY DIAMETER, MM (IN)							
		180-300 (7-12)	300-400 (12-16)	450-600 (18-24)	600-750 (24-30)	760-970 (30-40)	1010-1400 (40-56)		
		Belt speed, m/s (FPM)							
mm	(in)	<6,1 (1200)	<6,1 (1200)	<6,1 (1200)	<6,1 (1200)	<6,1 (1200)	<7,5 (1500)	<6,1 (1200)	<7,5 (1500)
300-400	12-16	1	2	N/A	N/A	N/A	N/A	N/A	N/A
400-500	16-20	1	2	3	N/A	N/A	N/A	N/A	N/A
500-650	20-26	1	2	3	3	N/A	N/A	N/A	N/A
650-800	26-32	1	2	3	3	N/A	N/A	N/A	N/A
800-1000	32-40	1	2	3	3	N/A	N/A	N/A	N/A
1000-1200	40-48	N/A	2	3	3	4	5	4	5
1200-1400	48-56	N/A	2	3	3	4	5	4	5
1400-1600	56-64	N/A	2	3	3	4	5	4	5
1600-1800	64-72	N/A	N/A	3	3	4	5	4	5
1800-2000	72-80	N/A	N/A	3	3	4	5	4	5
2000-2200	80-88	N/A	N/A	3	3	4	5	4	5

## Types of URETHANE BLADE

Polyurethane blades offer effective cleaning in conveyor belt systems. They have application in coal plants, steel mills, iron mines, and other industries. The type of polyurethane is adjusted according to the requirements of operation, type of material and temperature.

For a proper selection of the belt cleaner, it is recommended to fill out the Belt Cleaner Data Sheet, which is available at the end of the catalog, so that our Technical Department can offer you the most appropriate polyurethane blade for the needs of your system.

\* Our factory can produce polyurethanes specially adapted for other conditions and applications. For more information you can consult the Technical Department of LUFH-CBS.

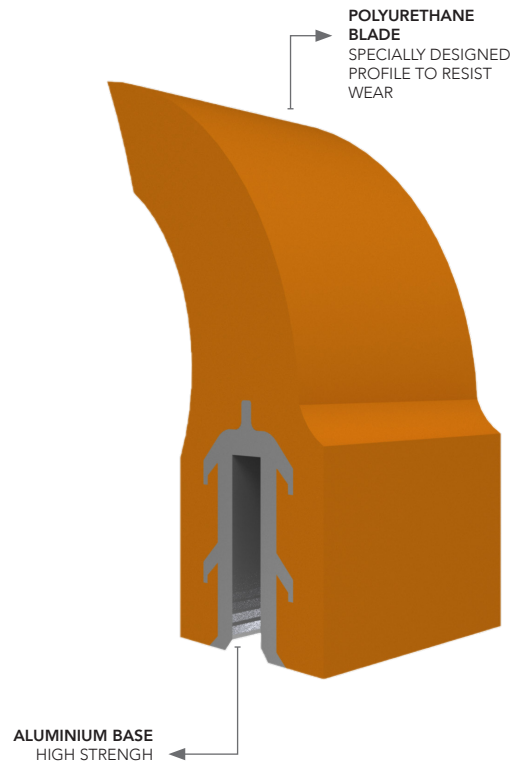
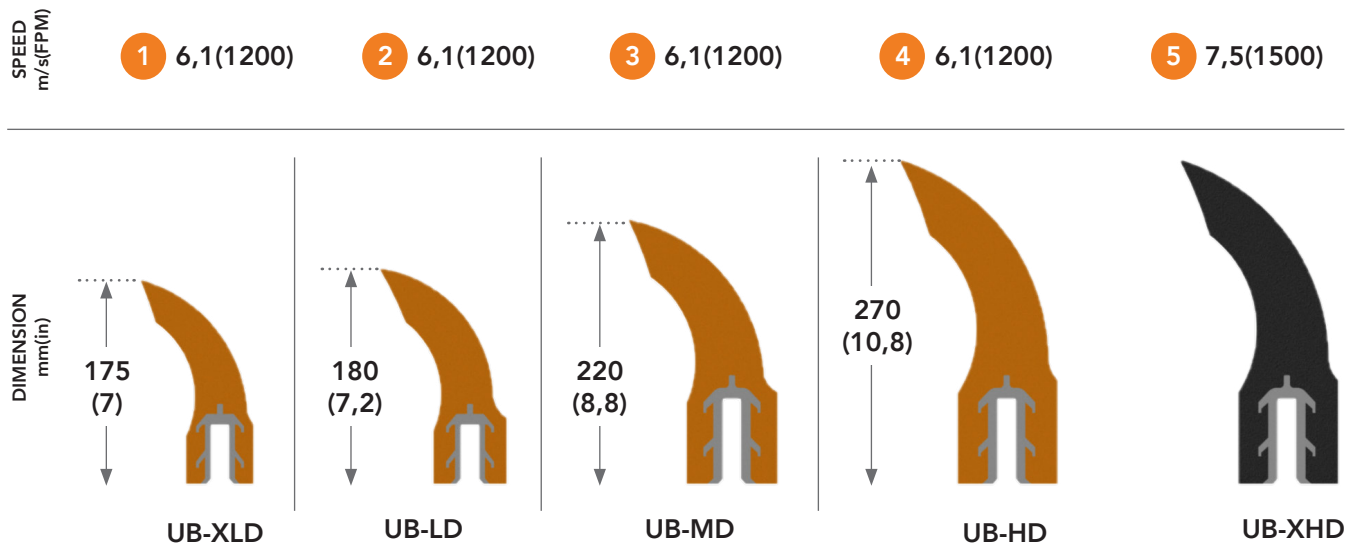

Figure 1. Maximum speed according to type of primary urethane belt cleaner m/s (FPM)



N°	Product	Pulley diameter mm (in)	Belt width mm (in)	Maximum belt speed m/s (FPS)	Temperature range
1	UB-XLD	<300 (<12)	<1000 (<36)	<6,1 (1200)	-20°/107°C (-4°/225°F)
2	UB-LD	<400 (<16)	<1600 (<54)	<6,1 (1200)	-20°/107°C (-4°/225°F)
3	UB-MD	450-750 (18-30)	<2200 (<84)	<6,1 (1200)	-20°/107°C (-4°/225°F)
4	UB-HD	760-1400 (30-56)	<2200 (<84)	<6,1 (1200)	-20°/107°C (-4°/225°F)
5	UB-XHD	760-1400 (30-56)	<2200 (<84)	<7,5 (1500)	-20°/148°C (-4°/300°F)



## H- Type razor-back BELT CLEANERS

The rubber belt cleaners with sintered tungsten carbide tip, known as the H-Type, offer an effective cleaning of the belt due to its damping system. They are capable of removing more than 90% of the fine bulk material that remain attached to the belt. The thin metal blades resist the impacts of the joints and provide a long service life, are economical and, being separable, facilitate the maintenance and repair of the assembly.

LUFH models are available for conveyor belts width from 300 to 2400 mm (12 to 95 in), and can operate with belt speeds of 6.1 m/s (1200 FPM) and temperatures between -28 ° / 204 ° C (20 ° / 400 ° F).

### SELECTION GUIDE

- For the proper selection of a type H primary cleaning system, the following data is required:
- Belt width.
- Pulley diameter where the system will be installed.
- Speed of the conveyor belt.
- Type of bulk material.
- Operating temperature.

Once the data of the transporter has been collected, proceed as follows:

1. The number of the type of blade is chosen according to the width of the belt and the diameter of the head pulley (See Table 2)
2. The selection of the blade is corroborated with the maximum speed of the belt (See Figure 2)
3. According to the selected blade, the tip of the cleaner is chosen and the number of blades required is specified (See Table 3).

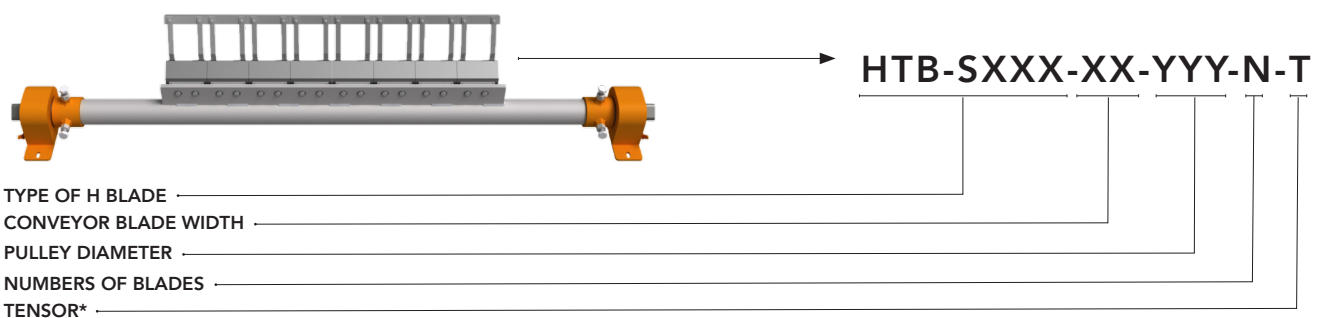

\* See section Tensioners Devices for coding of available tensioners. If you wish to receive help in the selection, you can consult the Technical Department of LUFH-CBS.

**Table 2.** Selection guide for primary H-type belt cleaner

Belt width		HEAD PULLEY DIAMETER, MM (IN)							
		Belt speed, m/s (FPM)							
mm	(in)	<300 (<12)	300-400 (12-16)	400-450 (16-18)	450-560 (18-22)	560-600 (22-24)	600-760 (24-30)	760-810 (30-32)	810-1220 (32-46)
300-400	12-16	1	2	3	N/A	N/A	N/A	N/A	N/A
400-500	16-20	1	2	3	4	N/A	N/A	N/A	N/A
500-650	20-26	1	2	3	4	4	5	N/A	N/A
650-800	26-32	1	2	3	4	4	5	N/A	N/A
800-1000	32-40	1	2	3	4	4	5	N/A	N/A
1000-1200	40-48	1	2	3	4	4	5	6	7
1200-1400	48-56	N/A	2	3	4	4	5	6	7
1400-1600	56-64	N/A	N/A	N/A	5	5	6	6	7
1600-1800	64-72	N/A	N/A	N/A	5	5	6	6	7
1800-2000	72-80	N/A	N/A	N/A	5	5	6	6	7
2000-2200	80-88	N/A	N/A	N/A	5	5	6	6	7
2200-2400	88-96	N/A	N/A	N/A	5	5	6	6	7

## Type of H BLADES

LUFH offers different types of tungsten carbide blade according to each application.

For more information about our H-Type blades you can consult the Technical Department of LUFH-CBS.

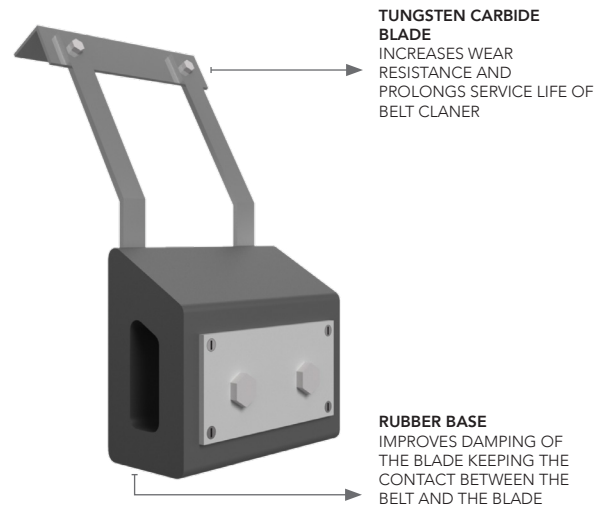

Figure 2. Maximum speed according to primary H-type primary belt cleaner

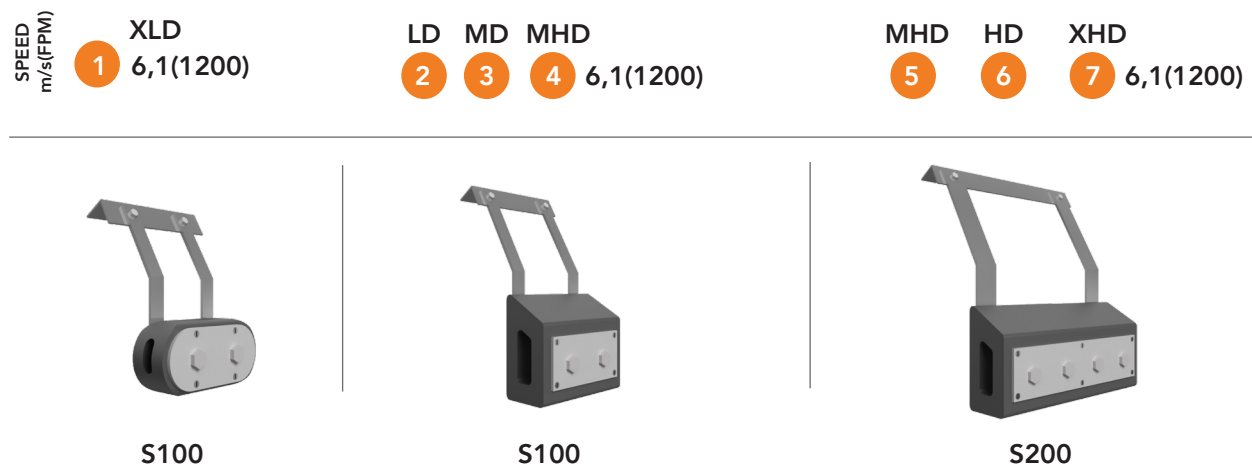

Table 3. Selection guide to determine the number of H-type blades required

Cleaner tip length mm (in)	500 (20)	650 (26)	1000 (40)	1200 (48)	1400 (56)	1600 (64)	1800 (72)	2000 (80)	220 (88) 0	2400 (96)
S100	4	5	9	10	12	14	N/A	N/A	N/A	N/A
S200	N/A	N/A	N/A	5	6	7	8	9	10	11

N°	Product	Dimensions mm (in)	Pulley diameter mm (in)	Belt width mm (in)	Maximum belt speed, m/s (FPS)	Temperature range
1	HTB-S100-XLD	100x150 (4x6)	<400 (<16)	(1200) (<48)	6,1 <1200	-28°/204°C (-20°/400°F)
2	HTB-S100-LD	100x218 (4x9)	400-600 (16-24)	<1200 (<48)	6,1 (1200)	-28°/204°C (-20°/400°F)
3	HTB-S100-MD	100x240 (4x10)				
4	HTB-S100-MHD	100x268 (4x11)				
5	HTB-S200-MHD	200x240 (8x10)	>600 (>24)	<3000 (<120)	6,1 (1200)	-28°/204°C (-20°/400°F)
6	HTB-S200-HD	200x268 (8x11)				
7	HTB-S200-XHD	200x295 (8x12)				





**SECONDARY  
BELT CLEANERS**



Secondary belt cleaners remove the fine-grained material that remains after cleaning by the primary cleaning system. Depending on the operating conditions required for the conveyor, more than one of these belt cleaners can be used\*.

These belt cleaners are installed below the head pulley, where the belt decreases its contact with the pulley. This point is normally close to the material flow so that the leftover material removed by the cleaning system can be returned back to the material discharge.

Occasionally, secondary belt cleaners are placed away from the point of discharge of the material. In these cases, to return the material to its flow, vibrating hoppers are required.

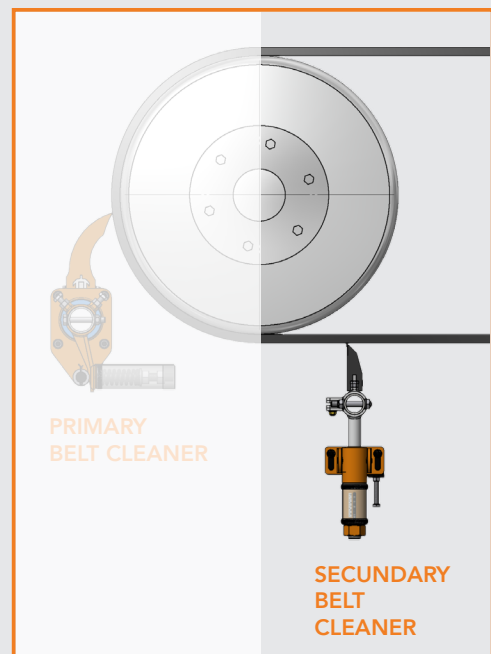

**\*NOTE:** To improve the degree of cleaning of the belt, other belt cleaners, known as tertiary belt cleaners, can be installed. These belt cleaners do not have to be the same model as the secondary ones. Your selection depends on the degree of cleanliness desired and the space available. Since tertiary belt cleaners are located away from the head pulley, they have to be installed next to a tension pulley. Thanks to the back pressure of the tension pulley, the belt is prevented from rising due to the pressure of the cleaner.

For more information on secondary and tertiary belt cleaners you can consult the Technical Department of LUFH-CBS



## P-Type rubber blade

### RAZOR BACK BELT CLEANERS

This cleaner has a rubber cartridge with a sintered tungsten carbide tip, which facilitates the replacement of the cleaning system blade and provides a longer life for the belt. Fast blade replacement minimizes maintenance and repair costs. The model can come in two presentations according to customer requirements: Type 1 with cartridge lengths of 100 mm (4 in) and 200 mm (8 in); and Type 2 with 400 mm (16 in). The models use rubber tensioners that maintain a constant pressure between the blade and the belt, ensuring the removal of fine grain material.

It is used in belts of widths less than 3000 mm (120 in), speeds up to 6.1 m/s (1200 FPM) and temperatures between -28 ° / 204 ° C (-20 ° / 400 ° F).

#### SELECTION GUIDE

For the proper selection of a P-type rubber blade, the following data is required:

- . Belt width.
- . Head pulley diameter.
- . Speed of the conveyor belt.
- . Type of bulk material.
- . Operating temperature.

Once the data of the belt conveyor has been collected, proceed as follows:

1. The type of blade is chosen according to the characteristics of the conveyor (See Figure 3)
2. According to the selected blade and belt width, the number of blades required is specified (See Table 4)

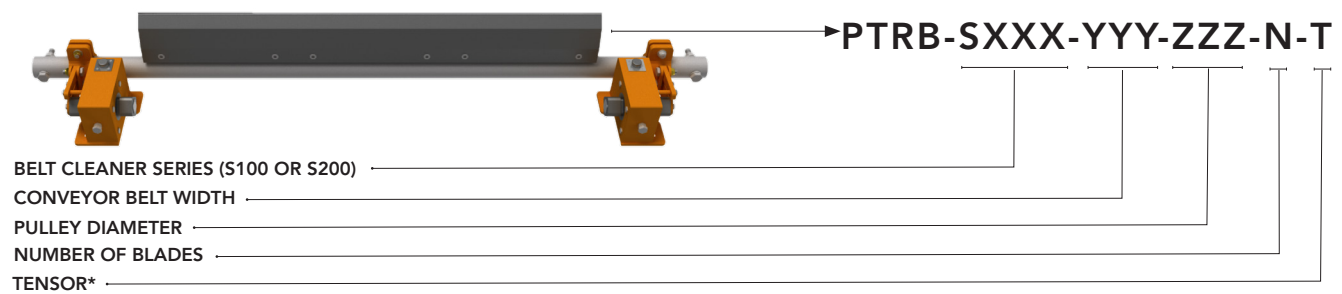

\* See section Tensioners Devices for coding of available tensioners. If you wish to receive help in the selection, you can consult the Technical Department of LUFH-CBS.

Figure 3. Type of P rubber blades

	S100-LD	S200-MD	S400-HD
LENGTH mm (in)	100 (4)	200 (8)	400 (16)
TIP THICKNESS mm (in)	3 (0,2)	3 (0,12)	4 (0,40)
BELT WIDTH mm (in)	<3000 (<120)	<3000 (<120)	<3000 (<120)
MAXIMIM BELT SPEED, m/s (FSP)	6,1 (1200)	6,1 (1200)	6,1 (1200)
TEMPERATURE RANGE	-28°/204°C (-20/400°F)	-28°/204°C (-20/400°F)	-28°/204°C (-20/400°F)

Table 4. Selection guide to determine the number of P rubber blades required

Belt width mm (in)	S100-LD	S200-MD	S400-HD
400 (16)	4	N/A	N/A
500 (20)	5	N/A	N/A
650 (26)	7	N/A	N/A
800 (32)	8	4	2
1000 (40)	10	5	2.5
1200 (48)	12	6	3
1400 (56)	14	7	3.5
1600 (64)	16	8	4
1800 (72)	18	9	4.5
2000 (80)	20	10	5
2200 (88)	22	11	5.5
2400 (96)	24	12	6

## P-Type urethane blade

### RAZOR-BACK BELT CLEANERS

These belt cleaners feature a polyurethane blade and pre-tensed rubber tensioners that maintain a constant pressure between the blade and the belt. The chemical composition of the polyurethane blade reduces the amount of adhered material, ensuring the cleaning effect for long periods of time.

The model comes in two presentations: blade divided into segments and as a single blade. The design of the set allows a quick replacement of the blades minimizing maintenance and repair costs.

#### SELECTION GUIDE

For the proper selection of P-type urethane blade, the following data is required:

- . Belt width.
- . Head pulley diameter.
- . Speed of the conveyor belt.
- . Type of bulk material.
- . Operating temperature.

Once the data of the conveyor belt has been collected, proceed as follows:

1. The type of blade is chosen according to the characteristics of the conveyor (See Figure 4)
2. According to the selected blade and the belt width, the number of blades required is specified (See Table 5)

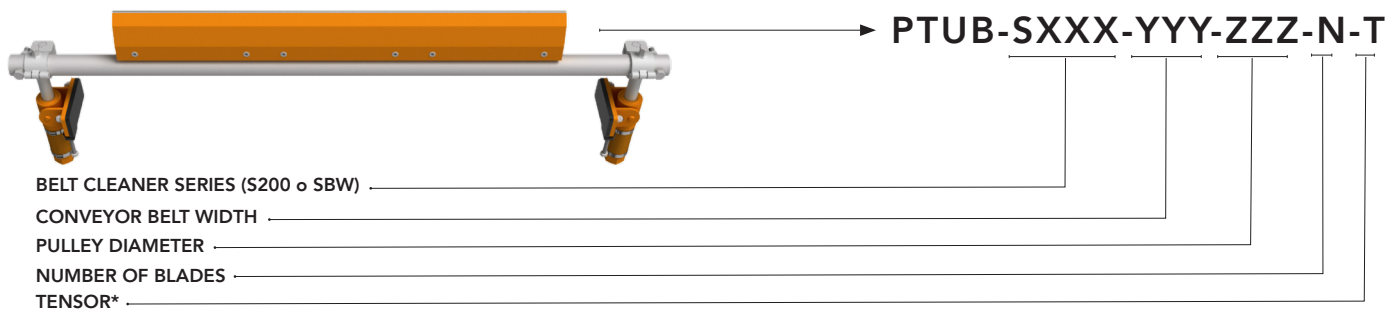

\* See section Tensioners Devices for coding of available tensioners. If you wish to receive help in the selection, you can consult the Technical Department of LUFH-CBS.

Figure 4. Type of P urethane blades

	SPLIT BLADE S200	SINGLE BLADE SBW
TIP THICKNESS mm (in)	3 (0,12)	3 (0,12)
BELT WIDTH mm (in)	<2200 (<88)	<2200 (<88)
MAXIMUM BELT, m/s (FSP)	6,1 (1200)	6,1 (1200)
TEMPERATURE RANGE	-28°/108°C (-20/225°F)	-28°/108°C (-20/225°F)

Table 5. Selection guide to determine the number of P urethane blades required

	SPLIT BLADE S200	SINGLE BLADE SBW
Belt width mm (in)	Number of blades	Blade length, mm (in)
400 (16)	N/A	400 (16)
500 (20)	N/A	500 (20)
650 (26)	N/A	650 (26)
800 (32)	4	800 (32)
1000 (40)	5	1000 (40)
1200 (48)	6	1200 (48)
1400 (56)	7	1400 (56)
1600 (64)	8	1600 (64)
1800 (72)	9	1800 (72)
2000 (80)	10	2000 (80)
2200 (88)	11	2200 (88)

# U-Type URETHANE CLEANER

This cleaner is characterized by having a polyurethane blade with sintered tungsten carbide tip. Its spring tensioners allow a constant pressure between the blade and the belt.

The design of the set facilitates the replacement of the blade, minimizing maintenance and repair costs.

The application of the U-type cleaner is intended for belts of widths less than 2000 mm (80 in), belt speeds up to 6.1 m/s (1200 FPM), and temperature ranges between -28 ° / 108 ° C (-20 ° / 225 ° F).

## SELECTION GUIDE

For the proper selection of a U-type belt cleaner, the following data is required:

- . Belt width.
- . Head pulley diameter.
- . Speed of the conveyor belt.
- . Type of bulk material.
- . Operating temperature.

Once the data of the belt conveyor has been collected, proceed as follows:

1. The type of blade is chosen according to the characteristics of the conveyor, in particular depending on the width of the belt (See Table 6)

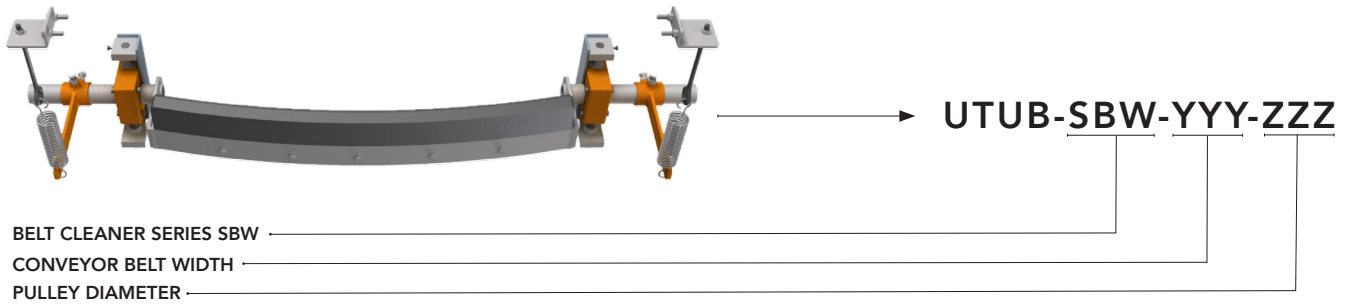

Table 6. Selection guide to determine U-type belt cleaner

Model	Belt width, mm (in)	Discharge chute width, mm (in)
UTUB-SBW-800	800 (32)	1600 (64)
UTUB-SBW-1000	1000 (40)	1800 (72)
UTUB-SBW-1200	1200 (48)	2160 (86)
UTUB-SBW-1400	1400 (56)	2360 (94)
UTUB-SBW-1600	1600 (64)	2560 (102)
UTUB-SBW-1800	1800 (72)	2760 (110)
UTUB-SBW-2000	2000 (80)	2960 (118)
UTUB-SBW-2200	2200 (88)	3160 (126)







## SPECIALITY CLEANERS

In non-common applications, speciality belt cleaners may be required. LUFH-CBS offers alternative solutions for these cases according to customer requirements.



## Ceramic scraper BELT CLEANERS

These belt cleaners have ceramic inserts that are in more efficient contact with the conveyor belt, reducing friction. They offer a high-quality cleaning after installation. These are resistant to abrasion and have a long service lifespan. The installation of ceramic scraper belt cleaners is different for each application, since it depends on the width of the belt and the diameter of the head pulley. Usually, if the width of the belt is less than 1400 mm (55 in), they are installed diagonally, while for larger widths they are installed in a V-shape.

Since installation work is simple, maintenance costs are reduced.

### SELECTION GUIDE

For the proper selection of a ceramic scraper belt cleaner, the following data is required:

- . Belt width
- . Head pulley diameter
- . Conveyor belt speed
- . Type of bulk material
- . Operating temperature
- . Material discharge chute width

Once the conveyor data is collected, the type of model that matches the width of the conveyor belt is selected (See Table 7).

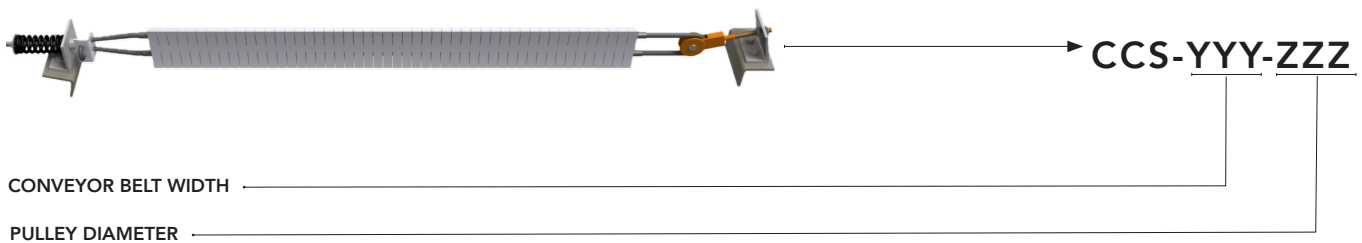
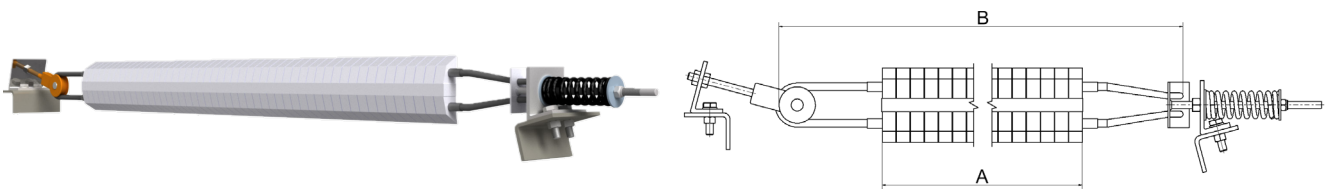

Table 7. Selection guide to determine ceramic scraper belt cleaner

Model	Belt width, mm (in)	Number of ceramic inserts	Total length of ceramic inserts, "A" mm (in)	Total length of steel cables, "B" mm (in)
CCS-750	750 (30)	31	733 (29)	2900 (80)
CCS-900	900 (36)	37	875 (35)	3400 (136)
CCS-1000	1000 (40)	42	994 (39)	3600 (144)
CCS-1050	1050 (42)	23	1018 (41)	3900 (156)
CCS-1200	1200 (48)	50	1184 (47)	4100 (164)
CCS-1400	1400 (56)	59	1397 (55)	4600 (184)
CCS-1600	1600 (64)	67	1586 (63)	5000 (200)
CCS-1800	1800 (72)	75	1776 (71)	5400 (216)

## C-Type BELT CLEANERS

The C-type belt cleaners automatically adjust to the different conditions of the conveyor belt. The tip and support overlay design allow precise cleaning that leaves no spaces uncovered.

When the cleaner meets an irregular or worn surface of the belt, the direction of the blades is adjusted according to the condition of the belt. Thus, in case of anomalies in the conveyor system, belt damage is reduced thanks to this automatic orientation of the assembly.

These self-adjusting and flexible belt cleaners keep belt wear to a minimum. The C-type models make efficient cleaning possible and can be installed in any environment, even on small or very wide conveyors. Depending on the working conditions, the components of this cleaner can be assembled in the same place of installation.

### SELECTION GUIDE

For the proper selection of a C-type cleaner, the following data is required:

- . Belt width
- . Head pulley diameter
- . Conveyor belt speed
- . Type of bulk material
- . Operating temperature
- . Material discharge chute width

Once the conveyor data is collected, the type of model that matches the width of the conveyor belt is selected (See Table 8).

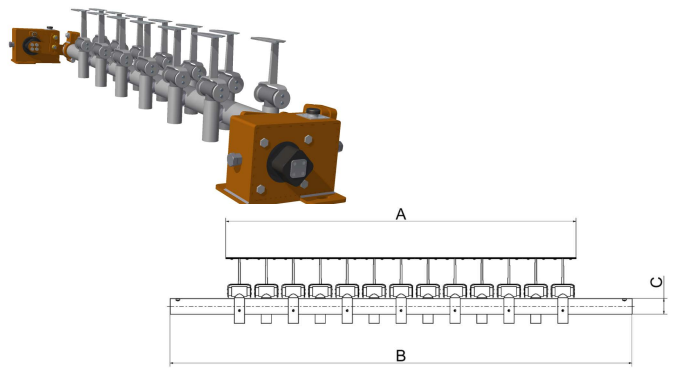

→ **CTB-YYY-ZZZ**

CONVEYOR BELT WIDTH

PULLEY DIAMETER

**Table 8.** Selection guide to determine C-type belt cleaner

Model	Belt width, mm (in)	Quantity of blades	"A" mm (in)	"B" mm (in)	"C" mm (in)
CTB-400	400 (16)	3	320 (12.6)	1200 (47.2)	60,5 (2,4)
CTB-500	500 (20)	4	420 (16.5)	1300 (51.2)	60,5 (2,4)
CTB-550	550 (22)	4	420 (16.5)	1350 (53.1)	60,5 (2,4)
CTB-600	600 (24)	5	520 (20.5)	1400 (55.1)	60,5 (2,4)
CTB-750	750 (30)	6	620 (24.4)	1500 (59)	60,5 (2,4)
CTB-800	800 (32)	6	620 (24.4)	1600 (63)	60,5 (2,4)
CTB-900	900 (36)	7	720 (28.3)	1700 (67)	60,5 (2,4)
CTB-1000	1000 (40)	8	820 (32.3)	1800 (71)	60,5 (2,4)
CTB-1050	1050 (42)	8	820 (32.3)	1800 (71)	60,5 (2,4)
CTB-1200	1200 (48)	10	1020 (40.2)	2000 (79)	60,5 (2,4)
CTB-1400	1400 (56)	12	1220 (48)	2200 (86.6)	60,5 (2,4)
CTB-1600	1600 (64)	14	1420 (56)	2400 (94.5)	76,3 (3,0)
CTB-1800	1800 (72)	15	1520 (60)	2600 (102.4)	76,3 (3,0)
CTB-2000	2000 (80)	17	1720 (67.7)	2800 (110.2)	76,3 (3,0)
CTB-2200	2200 (88)	19	1920 (75.6)	2980 (117.3)	76,3 (3,0)



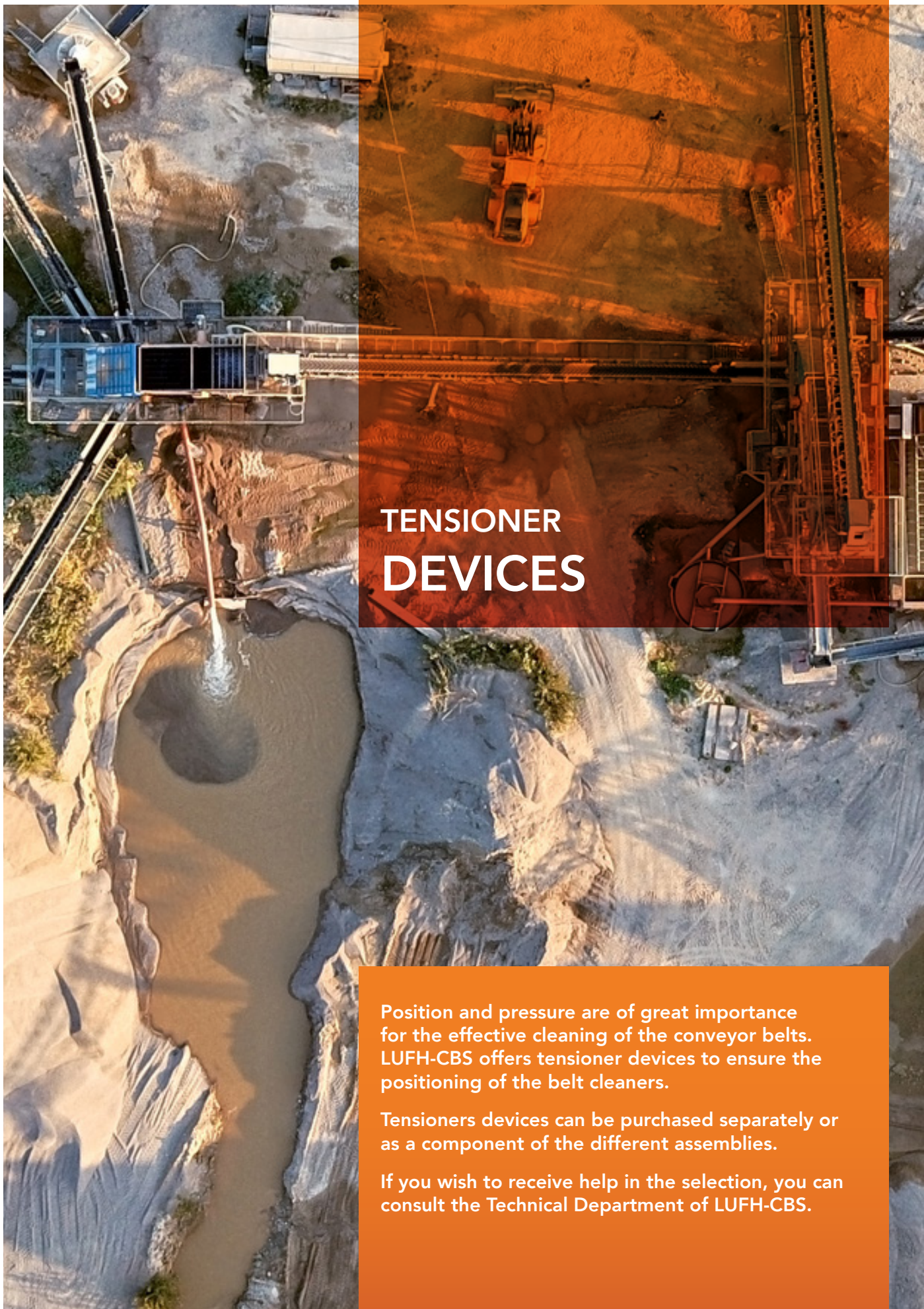

## TENSIONER DEVICES

Position and pressure are of great importance for the effective cleaning of the conveyor belts. LUFH-CBS offers tensioner devices to ensure the positioning of the belt cleaners.

Tensioners devices can be purchased separately or as a component of the different assemblies.

If you wish to receive help in the selection, you can consult the Technical Department of LUFH-CBS.

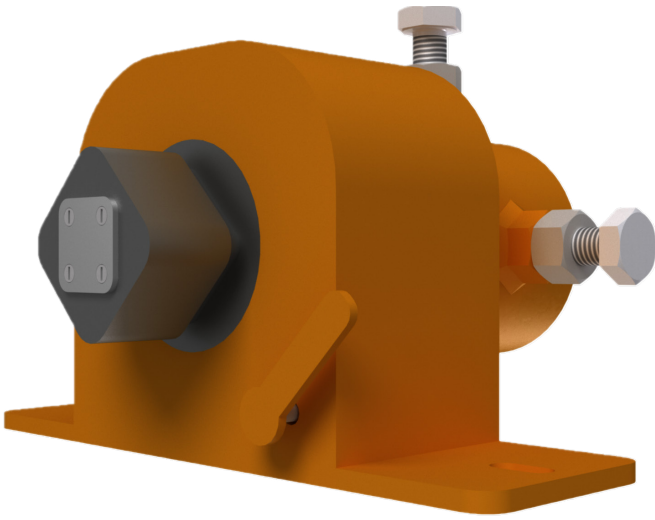

RUBBER TENSIONERS	BELT WIDTH MM (IN)
RT-1-WS	350-1000 (14-40)
RT-1-WMD	1050-1300 (42-52)
RT-1-WMU	1400-1600 (56-64)
RT-1-WL	1800-3000 (72-120)

## PRIMARY TENSORS

### RUBBER TENSORS

Rubber tensioners use an elastic rubber tensioning body. The tensioner is easy to install and adjust, even during the operation of the conveyor system. It is recommended for most primary and secondary belt cleaners.

The rubber tensioners offer effective cleaning for long periods of time by the use of its torsion pre-tensed rubber element. The selection of the tensioner depends on the width of the belt (See table below).

#### Benefits:

- . Single step maintenance. Rubber tensors are more elastic than the polyurethanes ones. Only one adjustment is required when you have a blade with wear.
- . Safe adjustments. Personnel are not at risk when adjusting with the belt in operation, since tensions can be changed without affecting other parts of the conveyor.



SPRING TENSIONERS	BELT WIDTH MM (IN)
ST-1-WS	350-1000 (14-40)
ST-1-WM	1050-1600 (42-64)
ST-1-WL	1800-3000 (72-120)

### SPRING TENSORS

These tensioners have a steel spring that is integrated into the main frame of the belt cleaner. Its use is aimed at mining applications. The contact pressure is adjusted manually, depending on the width and wear of the blade. The selection of the spring tensor depends on the width of the belt (See table below).

#### Benefits:

- . Adjustment accuracy. The internal steel spring provides the force that maintains the position of the cleaning system blade and ensures effective cleaning.
- . Compact design. Its small size and minimum height of the tensioner housing makes it suitable for limited space applications.



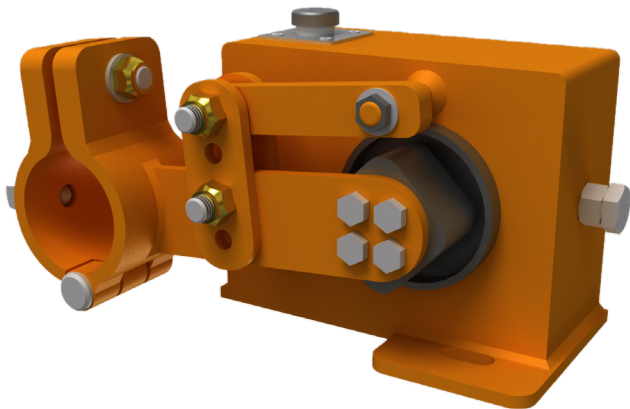

## SECONDARY TENSORS

### RUBBER TENSORS

The rubber tensioners offer effective cleaning for long periods of time by the use of its torsion pre-tensed rubber element. The selection of the tensioner depends on the width of the belt (See table below).

#### Benefits:

- Single step maintenance. Tensor rubber belts are more elastic than polyurethanes. Only one adjustment is required when you have a blade with wear.
- Safe adjustments. Personnel are not at risk when adjusting with the belt in operation, since tensions can be changed without affecting other parts of the conveyor.

RUBBER TENSIONERS	BELT WIDTH MM (IN)
RT-2-WS	350-1000 (14-40)
RT-2-WMD	1050-1300 (42-52)
RT-2-WMU	1400-1600 (56-64)
RT-2-WL	1800-3000 (72-120)

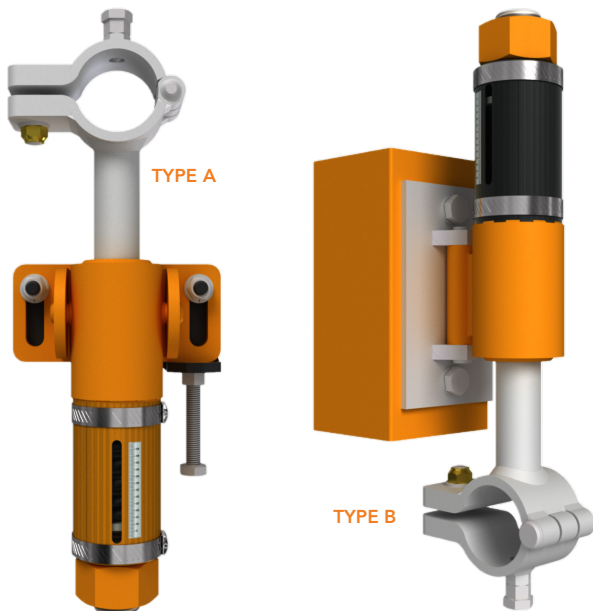

### SPRING TENSORS

The contact pressure is adjusted by pressing the cleaning system blade against the belt and rotating the tensioner housing. The contact pressure is adjusted manually, depending on the width and wear of the blade. The selection of the spring tensor depends on the width of the belt (See table below).

#### Benefits:

- Adjustment accuracy. The internal steel spring provides the force that maintains the position of the cleaning system blade and ensures effective cleaning.
- Compact design. Its small size and minimum height of the tensioner housing makes it suitable for limited space applications.

RUBBER TENSIONERS	BELT WIDTH MM (IN)
ST-2-WS-A/B	350-1000 (14-40)
ST-2-WM-A/B	1050-1600 (42-64)
ST-2-WM-A/B	1800-3000 (72-120)



# Belt cleaner

## BELT CLEANER DATA SHEET

**CLIENT INFORMATION**

COMPANY.....

CONTACT..... ADDRESS.....

COUNTRY..... STATE/CITY.....

PHONE..... EMAIL.....

APPLICATION REFERENCE NUMBER.....

**DIMENSIONES**

B.....  
BELT WIDTH mm (in)

L.....  
INTERNAL WIDTH OF DISCHARGE CHUTE mm (in)

D.....  
PULLEY DIAMETER mm (in)

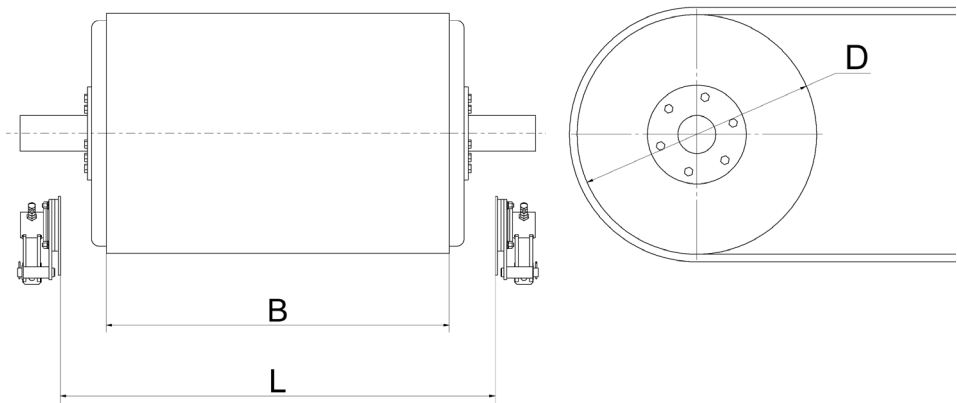

**PRODUCT REQUIRED**

BELT CLEANER SYSTEM  PRIMARY  SECONDARY  OTHER (TERTIARY, SPECIAL, ETC)

**TRANSPORTER INFORMATION**

EQUIPMENT (CARRIER REFERENCE NUMBER).....

BELT SPEED, M/S (FPM).....

SPLICE TYPE  VULCANIZED  MECHANICAL

REVERSIBLE BAND  YES  NO

CLEANERS INSTALLED  YES  NO MODEL (INDICATE BRAND AND MODEL).....

SHEET REPLACEMENT FREQUENCY (IN. QUANTITY / DAY; QUANTITY / YEAR; QUANTITY / TONS TRANSPORTED).....

PREVIOUSLY INSTALLED MODELS (INDICATE BRAND AND MODEL).....

FAILURES AND / OR PROBLEMS IN USED CLEANERS.....

**INFORMATION ON THE TRANSPORTED MATERIAL**

TYPE OF MATERIAL.....

THE MATERIAL IS ABRASIVE  YES  NO

CONDITIONS AND / OR PERCENTAGE OF HUMIDITY.....

MATERIAL TEMPERATURE..... °C (°F)

AMOUNT TRANSPORTED (TONS / HOUR).....

**OBSERVATIONS AND / OR COMMENTS**

.....

.....

.....



## COMMERCIAL OFFICES

---

### UNITED STATES OF AMERICA

Email: [sales@lufh-cbs.com](mailto:sales@lufh-cbs.com)

Address: 3508 NW 114 Ave, Doral, FL 33178, USA.

### UNITED ARAB EMIRATES

Email: [sales@lufh-cbs.com](mailto:sales@lufh-cbs.com)

Address: Compass Building, Al Shohada Road, AL Hamra Industrial Zone-FZ, Ras Al Khaimah, UAE.

### VENEZUELA

Email: [sales@lufh-cbs.com](mailto:sales@lufh-cbs.com)

Address: Zona industrial los Pinos, UD-301, Manzana 28, Parcela 9, Calle 6, Galpón 3, Puerto Ordaz, Estado Bolivar, Venezuela.

### COLOMBIA

Email: [sales@lufh-cbs.com](mailto:sales@lufh-cbs.com)

Address: Calle 77, N° 59 - 35, Oficina 11-08, Edificio Las Américas 3, Barranquilla, Atlántico, Colombia.

### GERMANY

Email: [sales@lufh-cbs.com](mailto:sales@lufh-cbs.com)

Address: Eigelstein 103-113, 50668 Koln.



[WWW.LUFH-CBS.COM](http://WWW.LUFH-CBS.COM)